

12mm Vibration Motor - 20mm Type  
Shown on 6mm Isometric Grid



## Product Data Sheet

### Uni Vibe™

## 12mm Vibration Motor - 20mm Type

**Model: 312-004**

### Ordering Information

The model number 312-004 fully defines the model, variant and additional features of the product. Please quote this number when ordering.

For stocked types, testing and evaluation samples can be ordered directly through our online store.

### Datasheet Versions

It is our intention to provide our customers with the best information available to ensure the successful integration between our products and your application. Therefore, our publications will be updated and enhanced as improvements to the data and product updates are introduced.

To obtain the most up-to-date version of this datasheet, please visit our website at:

[www.precisionmicrodrives.com](http://www.precisionmicrodrives.com)

The version number of this datasheet can be found on the bottom left hand corner of any page of the datasheet and is referenced with an ascending R-number (e.g. R002 is newer than R001). Please contact us if you require a copy of the engineering change notice between revisions.

If you have any questions, suggestions or comments regarding this publication or need technical assistance, please contact us via email at:

[enquiries@precisionmicrodrives.com](mailto:enquiries@precisionmicrodrives.com) or call us on +44 (0) 1932 252 482

### Key Features

Body Diameter:	12 mm [+/- 0.2]
Body Length:	20 mm [+/- 0.2]
Counterweight Radius:	3 mm [+/- 0.2]
Counterweight Length:	4 mm [+/- 0.2]
Shaft Orientation:	Inline
Rated Operating Voltage:	3 V
Rated Vibration Speed:	13,000 rpm [+/- 2,600]
Typical Rated Operating Current:	290 mA
Typical Normalised Amplitude:	5 G

### Typical Vibration Motor Performance Characteristics

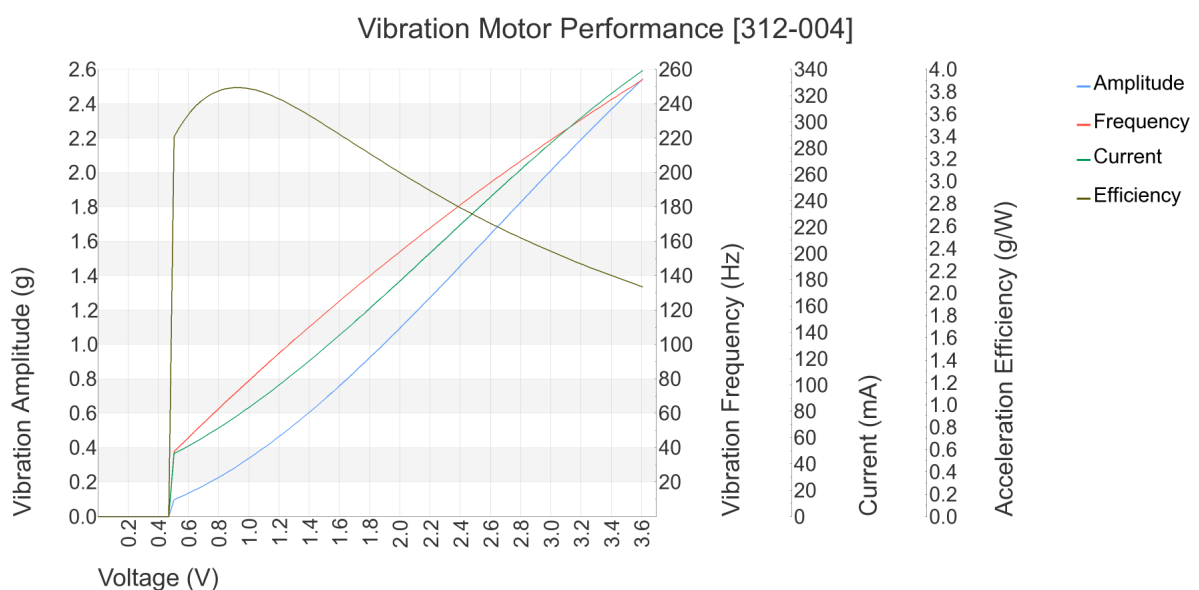

## Understanding Precision Microdrives Specification and Production Stages

### Precision Microdrives Specification Stages

Precision Microdrives is run on processes and we guide all customers through sets of predefined specification stages as they move from prototype to production. These are designed to allow the flexibility to iterate designs with the eventual certainty required for production parts.

Base	Sampling	Pre-Production	Production	EOL
Used for factory downselection Typically 0 units	Used for validating prototypes Typically ~ 10 units	Used for validating initial production Typically ~ 1k units	Used for validating mass production Typically >5k+ units	Used as basis for product replacement 'Base' spec Typically 0 units

## Precision Microdrives Capabilities and Competences

### Precision Motor Testing and Motor Testing Services

When we started PMD there were no commercial testing machines available, so we built our own. Ever since we've continued to develop new motor testing machines & procedures each year. Fast forward to today and we now have the most extensive testing facilities in the world for sub 40mm diameter motors, gear motors and vibration motors. These are used to validate motors through specification stages and during manufacturing. We also test motors as a service, provide easy to read reports and assist customers with their interpretation.



### Motor Customisation, Design, and Manufacturing

To be useful motors need to be integrated with other parts, such as housings or couplings. We routinely develop and produce complete assemblies, from motors with customised leads or connectors to complete electromechanical mechanisms and integrated control electronics. We will support and guide you through the specification stages from prototype to signing-off for mass production.



### Competent and Dependable Supply Chains for Production

Most of the world's miniature motors are made in Asia, and you need engineers on the factory floor who can maintain the Western values of "doing things right" whilst supporting the Asian values of "getting things done". As a customer you are supported by expert eyes, right at the heart of the manufacturing process where it is needed: On the ground in the UK, Hong Kong, and China.

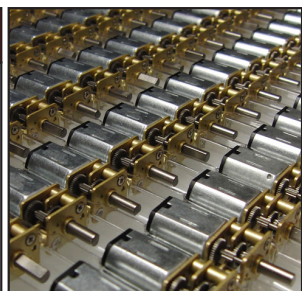

### Quality Engineers on the Ground and Local Engineering Teams

The nature of our business is to confidently produce and supply motors 'On time & To spec'. Our customers benefit from our certified ISO 9001 quality systems, reliable motor production infrastructure, and experience. We have a core competence in helping customers design out over-specified and expensive European drives, with more cost-effective, adequately specified, and verified Asian alternatives.



## Physical Specification

PARAMETER	CONDITIONS	SPECIFICATION
Body Diameter	Max body diameter or max face dimension where non-circular	12 mm [+/- 0.2]
Body Length	Excl. shafts, leads and terminals	20 mm [+/- 0.2]
Unit Weight		8.8 g
No. of Output Shafts		1
Counterweight Radius	Radius from shaft for non-cylindrical weights	3 mm [+/- 0.2]
Counterweight Length		4 mm [+/- 0.2]
Shaft Orientation		Inline

## Construction Specification

PARAMETER	CONDITIONS	SPECIFICATION
Motor Construction		Iron Core
Commutation		Precious Metal Brush
No. of Poles		3
Bearing Type		Sintered Bronze

## Operational Specification

PARAMETER	CONDITIONS	SPECIFICATION
Rated Operating Voltage		3 V
Rated Vibration Speed	At rated voltage using the inertial test load	13,000 rpm [+/- 2,600]
Max. Rated Operating Current	At rated voltage using the inertial test load	350 mA
Rated Inertial Test Load	Mass of standard test sled	250 g
Max. Start Voltage	With the inertial test load	1.1 V
Min. Vibration Amplitude	Peak-to-peak value at rated voltage using the inertial test load	1.4 G
Max. Operating Voltage		3.6 V
Max. Start Current	At rated voltage	1,070 mA
Min. Insulation Resistance	At 50V DC between motor terminal and case	1 MOhm

Important: The characteristics of the motor is the typical operating parameters of the product. The data herein offers design guidance information only and supplied batches are validated for conformity against the specifications on the previous page.

## Typical Performance Characteristics

PARAMETER	CONDITIONS	SPECIFICATION
Typical Rated Power Consumption	At rated voltage and load	870 mW
Typical Rated Operating Current	At rated voltage using the inertial test load	290 mA
Typical Vibration Amplitude	Peak-to-peak value at rated voltage using the inertial test load	2 G
Typical Start Current	At rated voltage	1,070 mA
Typical Vibration Efficiency	At rated voltage using the inertial test load	2.3 G/W
Typical Normalised Amplitude	Peak-to-peak vibration amplitude normalised by the inertial test load at rated voltage	5 G
Typical Start Voltage	With the inertial test load	1.6 V
Typical Terminal Resistance		2.3 Ohm
Typical Terminal Inductance		480 uH

## Typical Haptic Characteristics

PARAMETER	CONDITIONS	SPECIFICATION
Typical Lag Time	At rated voltage using the inertial test load	12 ms
Typical Rise Time	At rated voltage using the inertial test load	29 ms
Typical Stop Time	At rated voltage using the inertial test load	44 ms
Typical Active Brake Time	Time taken from steady-state to 0.04 G under inverse polarity at max. voltage	22 ms

## Typical Durability Characteristics

PARAMETER	CONDITIONS	SPECIFICATION
Typical Min. Counterweight Pullout		9.8 N
Typical Max. Mech. Noise		60 dB(A)

## Environmental Characteristics

PARAMETER	CONDITIONS	SPECIFICATION
Min. Operating Temp.		-10 Deg.C
Max. Operating Temp.		60 Deg.C
Min. Storage Temp.		-20 Deg.C
Max. Storage Temp.		70 Deg.C

## Typical Packing Conditions

PARAMETER	CONDITIONS	SPECIFICATION
Carton Type		Boxed Trays

## Product Dimensional Specification

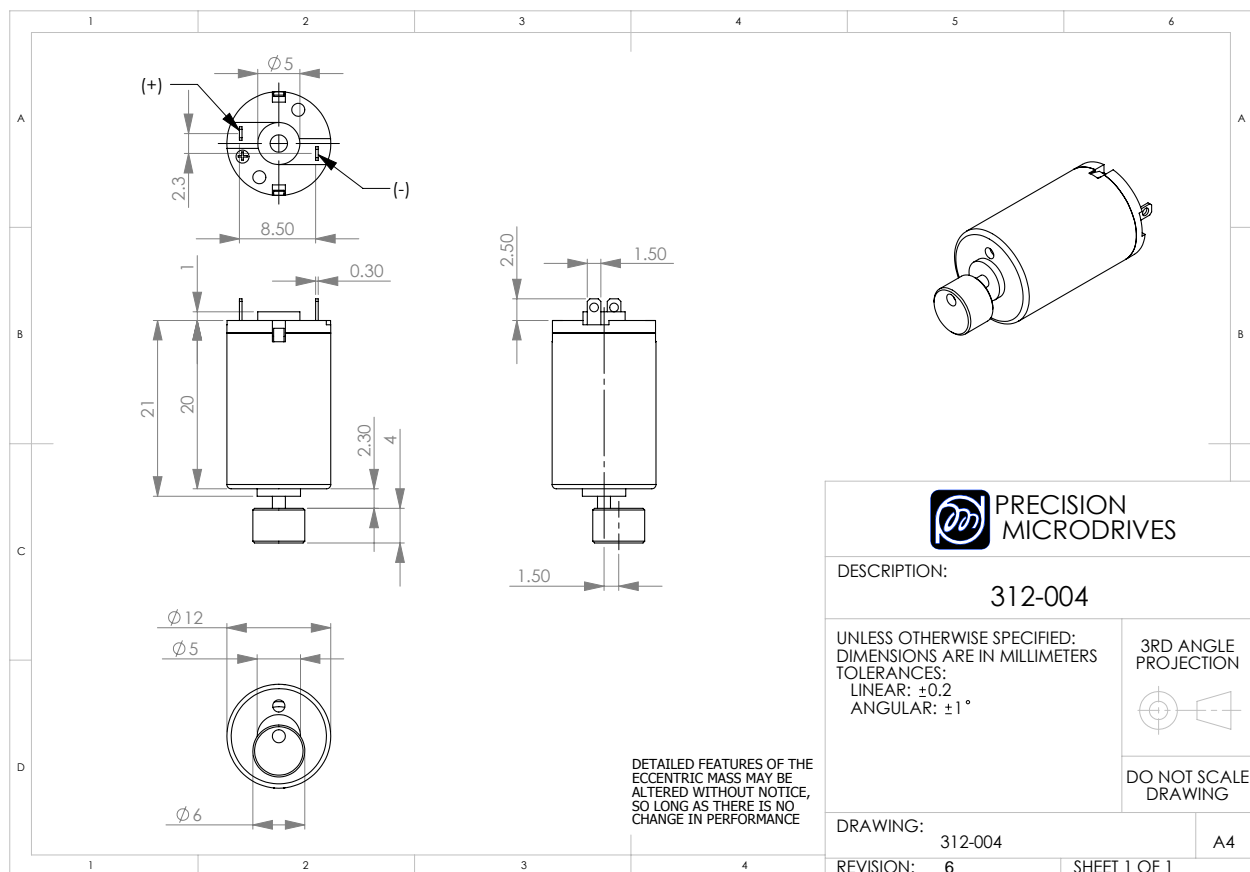

## Life Support Policy

PRECISION MICRODRIVES PRODUCTS ARE NOT AUTHORISED FOR USE AS CRITICAL COMPONENTS IN LIFE SUPPORT DEVICES OR SYSTEMS WITHOUT THE EXPRESS WRITTEN APPROVAL OF PRECISION MICRODRIVES LIMITED.

As used herein:

1. Life support devices or systems are devices or systems which, (a) are intended for surgical implant into the body, or (b) support or sustain life, and whose failure to perform when properly used in accordance with instructions for use provided in the labeling, can be reasonably expected to result in a significant injury to the user.
2. A critical component is any component of a life support device or system whose failure to perform can be reasonably expected to cause the failure of the life support device or system, or to affect its safety or effectiveness.



Precision Microdrives Limited  
 Canterbury Court, 1-3 Brixton Road  
 London  
 SW9 6DE  
 United Kingdom

Tel: +44 (0) 1932 252482  
 Fax: +44 (0) 1932 325353  
 Email: [enquiries@precisionmicrodrives.com](mailto:enquiries@precisionmicrodrives.com)  
 Web: [www.precisionmicrodrives.com](http://www.precisionmicrodrives.com)

Registered in England and Wales No. 5114621  
 VAT registration. GB 900 1238 84