

LA12 Linear Actuator Brushed (precious metal brushes)

Ø12mm motor body / integrated driver

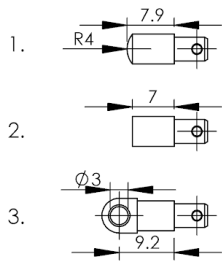

THREE TIPS AVAILABLE: 1. ROUND, 2. FLAT AND 3. EYELET

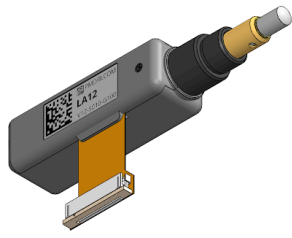
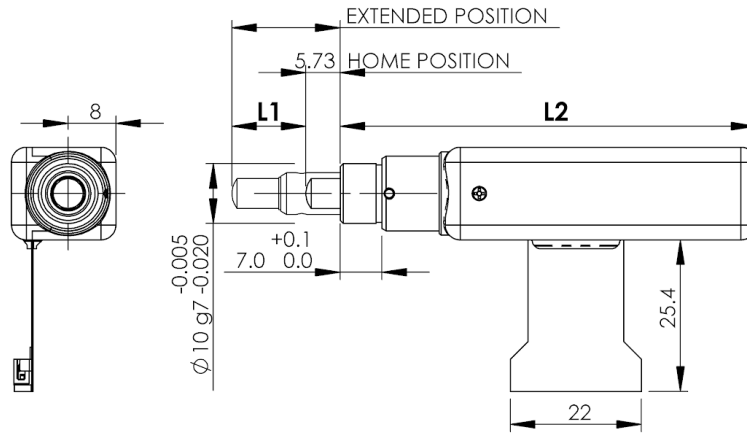

DIMENSIONS ARE IN mm

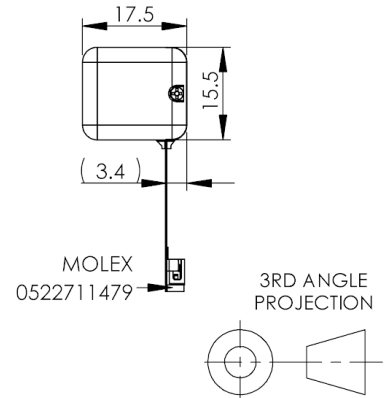

Series / frame size **L A 1 2** - Voltage option **V 1 2** - Stroke option **S 0 1 0** - Gearing option **G 0 3 0**

Design and accessories	Units		Custom design
A Availability		Stocked design	8 weeks
B Motor Type		Brushed	Brushed / brushless
C Commutation		Precious metal brush	To requirement
D Motor body diameter	mm	12.0	12.0
E Control method		2x PWM	
F Encoder counts / turn (at motor shaft)		12	To requirement
G Connections		Molex 0522711479	
H Cable		25mm FPCB	Please contact support@pmdri.com
I Body Material		Anodized aluminium alloy	
J Enclosure Housing		Polypropylene	

Voltage option		V18	V09	V06	
1 Nominal voltage	V	18	9	6	Nominal load, no load, and stall points will depend on the winding design. Please contact support@pmdri.com
2 Terminal resistance	Ω	31.6	7.5	3.2	
3 Terminal inductance	mH	5.24	1.25	0.60	
4 No load current	A	0.060	0.140	0.185	
5 Nominal current	A	0.160	0.285	0.415	
6 Stall current	A	0.550	0.900	1.100	

Stroke option (L1)		S010	S030	S050	
7 Stroke	mm	10	30	50	To requirement
8 Body length (L2)	mm	68.5	89.2	111.8	
9 Weight	g	38	50	63	
10 Max. radial load (extended)	N	50	40	30	

Gearing option		G010	G030	G100	
11 Max. speed (no load)	mm/s	20.7	7.10	2.20	Gearbox dependent
12 Nominal force	N	8	25	80	
13 Nominal speed (at nominal force)	mm/s	15.8	5.45	1.70	
14 Backdrive force	N	No backdrive	No backdrive	No backdrive	
15 Encoder linear resolution	um/count	4.167	1.389	0.421	
16 Repeatability	um	80	20	10	

Motor body characteristics		
17 Home sensor position	Fully retracted	
18 Home sensor technology	Magnetic	
19 Encoder technology	Magnetic	
20 Ambient temperature min.	°C	-10
21 Ambient temperature max.	°C	+50
22 Axial play at axial load	mm	0.2 max
23 Max. axial load (dynamic)	N	80

Operating range (based on ambient 25°C)

Speed / Force Curves

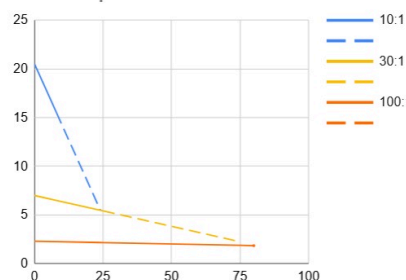

Current / Force Curves

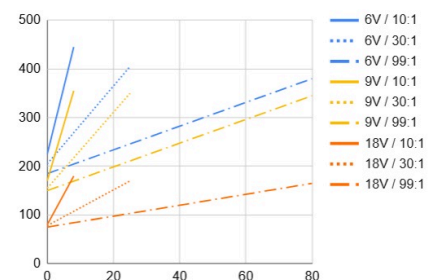

LA12 Linear Actuator Brushed (precious metal brushes)

Ø12mm motor body / integrated driver

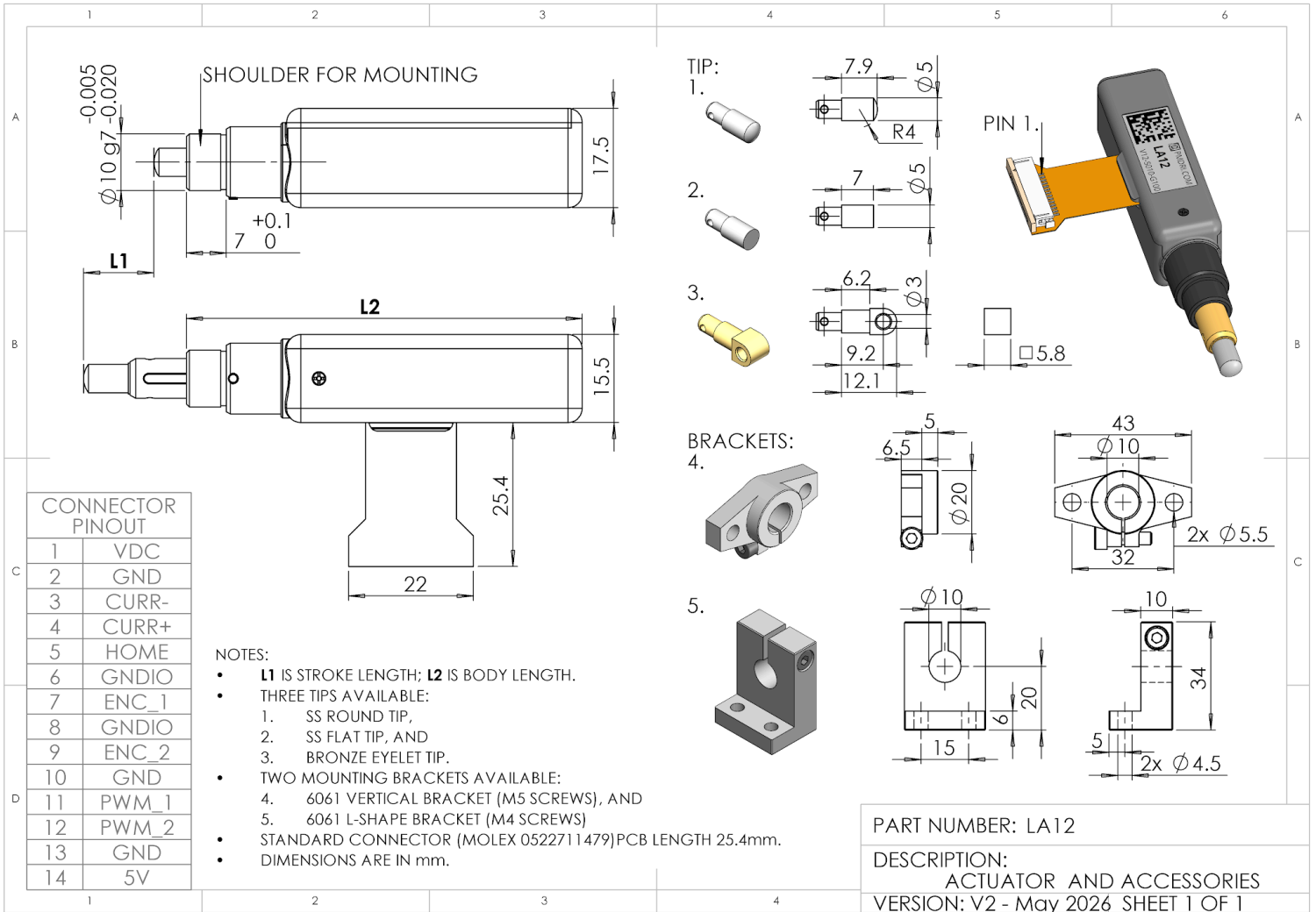

Accessories

A range of tips and mounting brackets are available for the actuator, to enable better integration into the end product and fast prototyping and testing

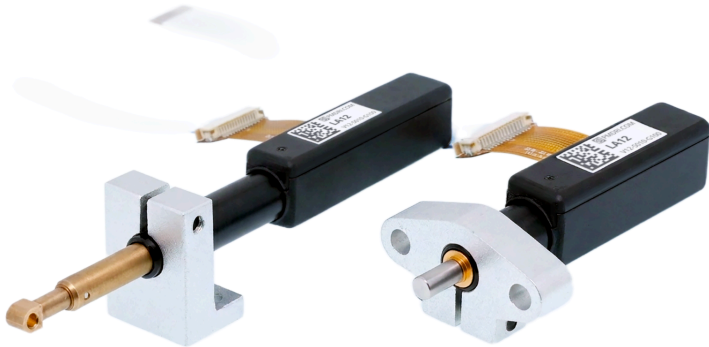

Actuator features

The actuator PCBA is equipped with the following features:

- Rotary incremental encoder
- Current monitor
- Home sensor

Rotary incremental encoder

The actuator contains a two-channel, hall-sensor based incremental encoder. The encoder is fitted on the motor body (before gearbox reduction) for increased resolution, and produces a quadrature output. In the extending direction, encoder channel 1 leads channel 2.

Current monitor

CURR+ / CURR- provide a differential signal proportional to the current flowing through the driver H-bridge. The conversion factor is 1 mA / mV e.g. a voltage output of 50mV corresponds to a motor current of 25mA.

Home sensor

The Home sensor triggers low when the actuator is in the fully retracted position. The Home sensor comprises of a neodymium magnet and high sensitivity Hall sensor, allowing it to achieve high repeatability.

Actuator driving

The actuator operates in PWM control mode. When running the actuator below 100% duty, during PWM off time, the actuator can either be set to:

- Coast - fast decay mode
- Brake - slow decay mode

Slow decay mode is typically used as it offers more linearity of actuator speed versus driving voltage, and in some cases improved efficiency.

PWM_1	PWM_2	OUT1	OUT2	DESCRIPTION
0	0	Hi-Z	Hi-Z	Cost (H-Bridge Hi-Z)
0	1	L	H	Reverse
1	0	H	L	Forward
1	1	L	L	Brake (Low-side slow decay)